



SafeRack

LOADING RACK TECHNOLOGIES

730 Electric Drive | Sumter | SC | USA | 29153 | +1-803-774-7225

M3 MAUI

Mobile Access Unit – Industrial Model



MAUI

Mobile Access Unit Industrial, for tank trucks, isotainers and railcars.

Do you need fall protection on top of trucks, isotainers or railcars, but the vehicle may be parked in varying locations?

Just roll the MAUI up to the vehicle and climb to the top in safety!

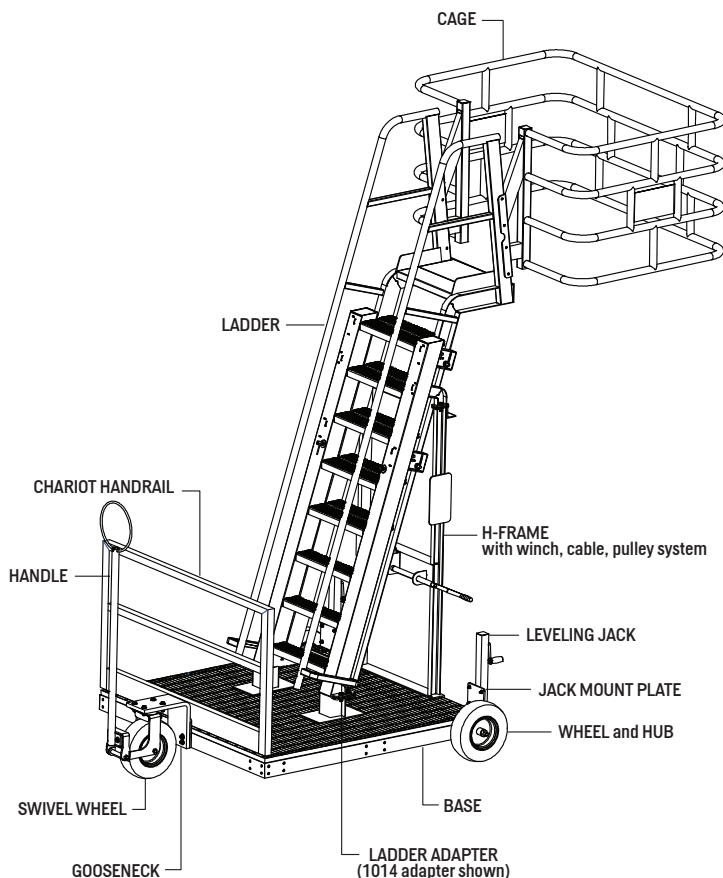

Only the SafeRack MAUI has this unmatched versatility.

- Support 187kg without resting on a vehicle, critical safety factor if the MAUI is used other than on a vehicle.
- Reconfigure on site to roll Parallel or Perpendicular to the vehicle if future use changes, no buying a new unit.
- Provides stability so operators will actually use the MAUI instead of complaining or not using it.
- Adjusts to fit vehicles of varying heights
- A choice of cages provide fall protection for trucks, isotainers or railcars.
- Never flat 406 mm tires, no flat spots.
- Winch with cover to Raise/Lower the ladder and cage assembly.
- Working range of MAUI 1014 is 3048mm to 4267mm.
- Optional adapter converts to 3658mm to 4877mm.
- Aluminum with galvanized base.

Zacatepetl 363 A, Delegación Tlalpan
14010 México, D.F. Tel- +52 (55)
5606-1611, e-mail:
promtec@promtec.com.mx



PROM TEC, S.A. DE C.V.



SafeRack

LOADING RACK TECHNOLOGIES

730 Electric Drive | Sumter | SC | USA | 29153 | +1-803-774-7225

M3 MAUI

Mobile Access Unit – Industrial Model

MAUI VERSATILITY

What if your future use changes? Reconfigure your MAUI.

What if you need to change the MAUI from rolling parallel to the vehicle to perpendicular?

Just change the wheels and you can use your MAUI in a different location!

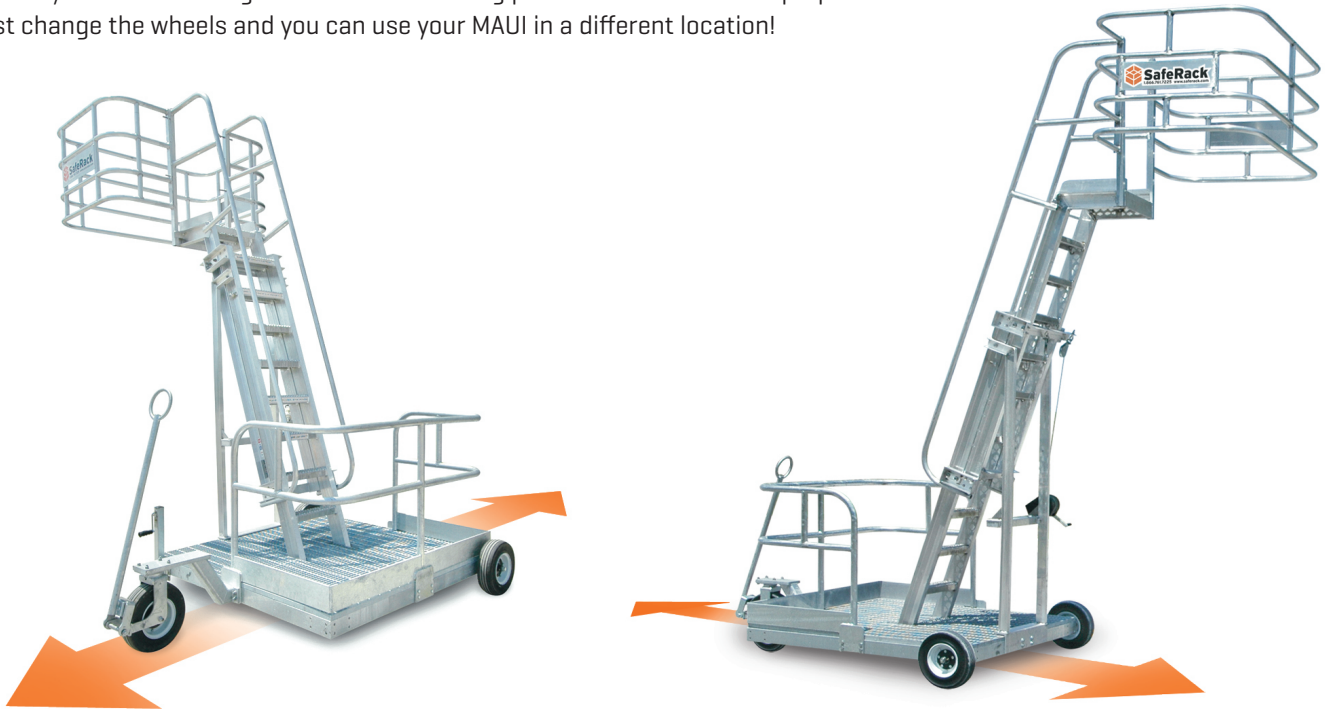

What if you need to use your MAUI on a railcar instead of a truck? Just change the cage?



When your operators find out how stable the MAUI is, will they use it for general maintenance work? Almost certainly the answer is YES! They can change light bulbs, do maintenance on valves or whatever and it will not tip over. It is self supporting for a load of 187 Kg.



PROM TEC, S.A. DE C.V.

Zacatepetl 363 A, Delegación Tlalpan
14010 México, D.F. Tel- +52 (55)
5606-1611, e-mail:
promtec@promtec.com.mx



SafeRack

LOADING RACK TECHNOLOGIES

730 Electric Drive | Sumter | SC | USA | 29153 | +1-803-774-7225

M3 MAUI

Mobile Access Unit – Industrial Model

Notes:

- 1) MAUI BASE TO BE HOT DIPPED GALVANIZED PER ASTM-A123
- 2) PLATFORM WALK SURFACE TO BE SERRATED AND SLIP RESISTANT
- 3) MAUI LADDER AND SAFETY CAGE SHALL BE OF ALUMINUM CONSTRUCTION
- 4) MAUI SHALL RAISE/LOWER BY USE OF HAND WINCH
- 5) LIVE LOAD CAPACITY NOT TO EXCEED 187 KG
- 6) ALL WELDS SHALL COMFORM TO AWS D1.1 - D1.6
- 7) STABILIZING JACKS, WHEELS & STEERING HANDLE CAN BE REPOSITIONED TO ALLOW PARALLEL POSITIONING. (SEE PLAN VIEW)

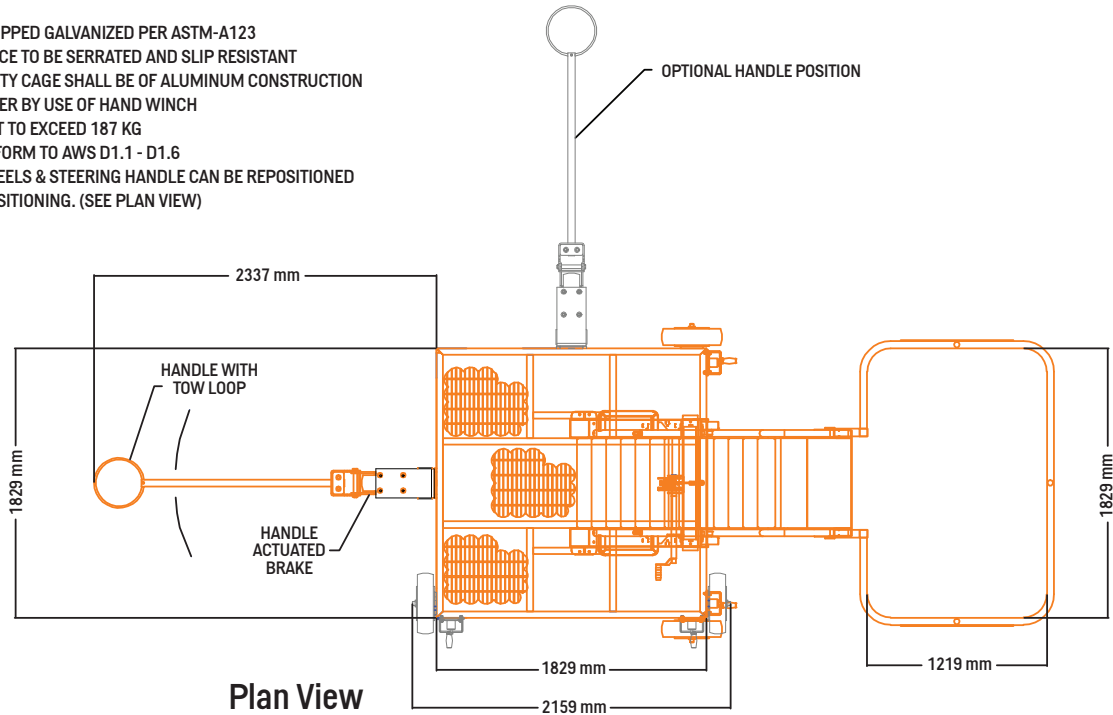

Plan View

M3 MAUI SPECIFICATION SHEET

DOC #M3-2011 REV4

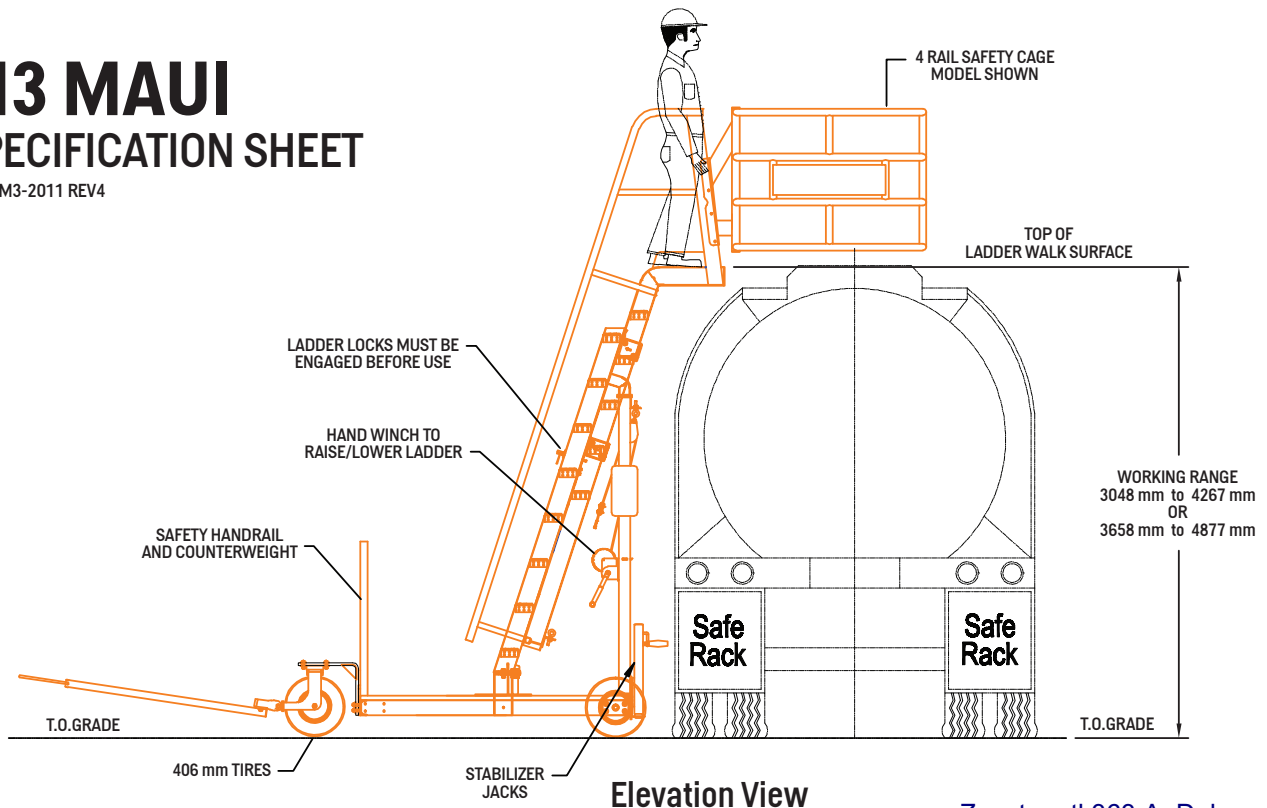

Elevation View

Zacatepetl 363 A, Delegación Tlalpan
14010 México, D.F. Tel- +52 (55)
5606-1611, e-mail:
promtec@promtec.com.mx



PROM TEC, S.A. DE C.V.